



US 20030025445A1

(19) **United States**

(12) **Patent Application Publication**  
**Lee**

(10) **Pub. No.: US 2003/0025445 A1**

(43) **Pub. Date: Feb. 6, 2003**

(54) **ORGANIC EL DISPLAY AND METHOD FOR MANUFACTURING THE SAME**

**Publication Classification**

(75) **Inventor: Jun-Yeob Lee, Chungsol town (KR)**

(51) **Int. Cl.<sup>7</sup> ..... H05B 33/00**

(52) **U.S. Cl. .... 313/503**

Correspondence Address:

**McGuireWoods**

**Suite 1800**

**1750 Tysons Boulevard**

**McLean, VA 22102-4215 (US)**

(57) **ABSTRACT**

An organic EL display includes an anode electrode; a cathode electrode; at least one organic layer selected from a hole transport layer, a hole injection layer, a light-emitting layer, an electron transporting layer, and an electron injection layer between the anode electrode and the cathode electrode; and at least one organic compound derivative layer arranged between the anode electrode and the cathode electrode, the organic compound derivative layer having a structure of formula:

(73) **Assignee: Samsung SDI Co., Ltd.**

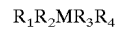

(21) **Appl. No.: 10/173,680**

, where "M" is one metal selected from a group consisting of Ti, Pt and one metal belonging to groups 3B and 4B of periods 3 to 5.

(22) **Filed: Jun. 18, 2002**

(30) **Foreign Application Priority Data**

Aug. 1, 2001 (KR) ..... 2001-046633

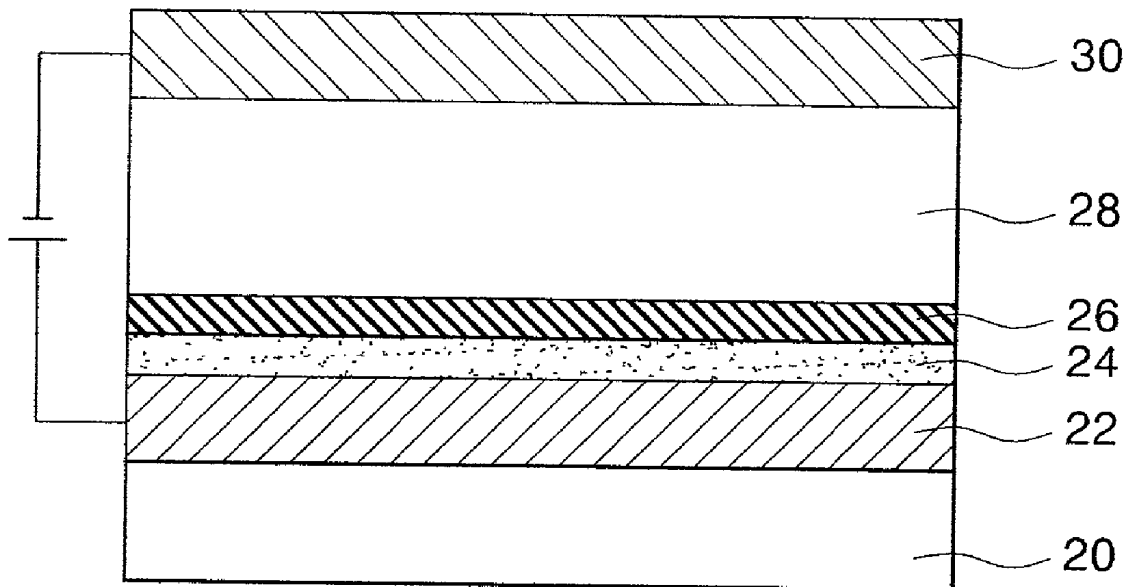

FIG. 1  
(PRIOR ART)

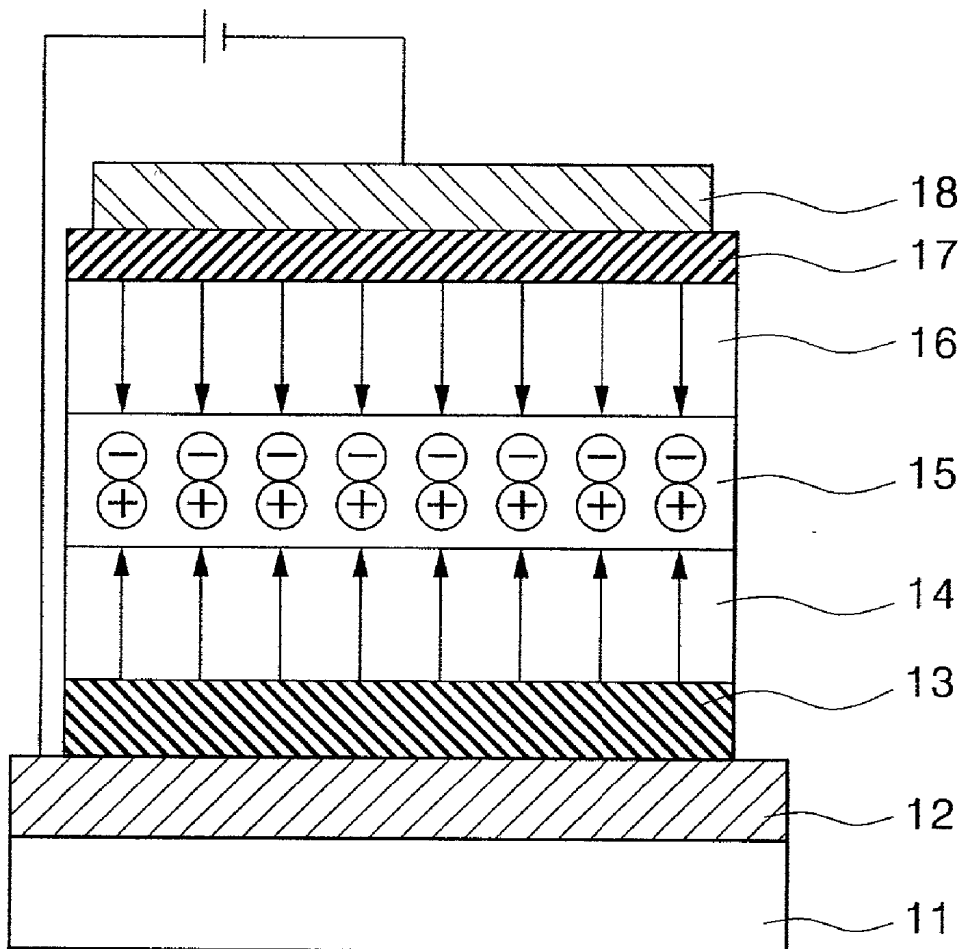
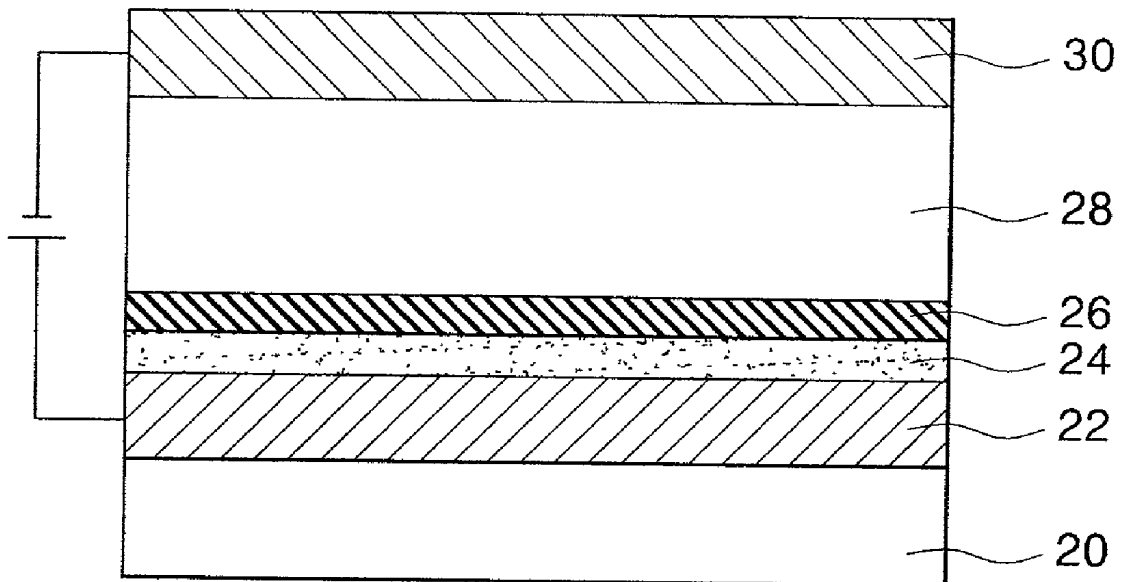

FIG. 2



## ORGANIC EL DISPLAY AND METHOD FOR MANUFACTURING THE SAME

### BACKGROUND OF THE INVENTION

[0001] 1. Field of the invention

[0002] The present invention relates to an organic EL display and a method of manufacturing the same.

[0003] 2. Description of Related Art

[0004] FIG. 1 is a cross-sectional view illustrating a conventional organic EL display, and particularly shows a low molecular organic EL display.

[0005] The organic EL display of FIG. 1 includes an anode electrode 12, a hole injection layer 13, a hole transport layer 14, an organic light-emitting layer 15, an electron transport layer 16, an electron injection layer 17, and a cathode electrode 18, which are stacked on a substrate 11 in described order. Of the layers, the electron transport layer 16 can be removed.

[0006] Eventhough not shown, a high molecular organic EL display generally includes an anode electrode, a hole transport layer, an organic light-emitting layer, and a cathode electrode, which are sequentially stacked.

[0007] Holes move from the anode electrode 12 to the organic light-emitting layer 15, and electrons move from the cathode electrode 18 to the organic light-emitting layer 15. The organic light-emitting layer 15 emits light by excitation and recombination of electrons and holes injected from a cathode and an anode. Therefore, if the hole injection efficiency and the electron injection efficiency are improved, the device characteristics of the organic EL display are also improved.

[0008] In the case of a low molecular organic EL display, the layers are formed using a vacuum deposition technique. However, in case of a high molecular organic EL display, the layers are formed using a solution processing technique, which result in certain limitations to forming the organic light-emitting layer made of an organic material.

[0009] In particular, the hole transport layer must be stable to a wet coating process to form the organic light-emitting layer using an organic solvent. The hole transport layer is generally made of a water-soluble high molecular material such as a PEDOT (a mixture of a poly(3,4)-ethylenedioxythiophene and a polystyrenesulfonate) or a PANI (a mixture of a polyaniline and a polystyrenesulfonate). However, such a hole transport layer has a problem in that an interface characteristic between the hole transport layer and the hydrophobic organic light-emitting layer is lowered.

[0010] For example, since a bonding power between the hole transport layer and the organic light-emitting layer is low, a life span of the organic EL display is shortened. Also, uniform organic light-emitting layer cannot be formed on the hydrophilic hole transport layer using an ink-jet printing technique or a laser induced thermal imaging (LITI) technique, even though the ink-jet printing technique and the LITI technique have an advantage in that it is easy to define pixels and achieve a full color light emission.

[0011] Another problem for the organic EL display is there is a poor interface characteristic between an anode electrode and a hole transport layer. Migration of oxygen from the

anode electrode to a hole transport layer or a light-emitting layer and permeation of moisture through the anode/hole transport layer or the hole transport layer/light-emitting layer interface can damage the device characteristic of the organic EL display.

[0012] In efforts to overcome the problems described above, a silicon oxide layer or a silicon nitride layer is arranged between the anode electrode and the hole transport layer so as to improve a device characteristic of the organic EL display.

[0013] U.S. Pat. No. 4,954,528 discloses a silicon carbide (SiC) layer arranged between the anode electrode and the hole transport layer. U.S. Pat. No. 4,188,565 discloses a silicon oxynitride layer arranged between the anode electrode and the hole transport layer. U.S. Pat. No. 5,643,685 discloses a silicon oxide layer arranged between the anode electrode and the hole transport layer. U.S. Pat. No. 5,476,725 discloses a tantalum oxide layer arranged between the anode electrode and the hole transport layer. However, the U.S. Patents stated above require a high vacuum process and have a complicated manufacturing process.

### SUMMARY OF THE INVENTION

[0014] To overcome the problems described above, preferred embodiments of the present invention provide an organic EL display with a hole transport layer having a high brightness. It is another object of the present invention to provide an organic EL display having a high efficiency.

[0015] It is another object of the present invention to provide an organic EL display having a lengthy life span.

[0016] It is another object of the present invention to provide an organic EL display having a simple manufacturing process.

[0017] In order to achieve the above object, the preferred embodiments of the present invention provide an organic EL display, comprising: an anode electrode; a cathode electrode; at least one organic layer selected from a hole injection layer, a hole transport layer, a light-emitting layer, an electron transport layer, and an electron injection layer between the anode electrode and the cathode electrode; and at least one organic compound derivative layer arranged between the anode electrode and the cathode electrode, the organic compound derivative layer having of the following formula:



[0018] , wherein "M" denotes one metal selected from a group consisting of Ti, Pt and one metal belonging to groups 3B and 4B of periods 3 to 5 of the periodic table, and "R<sub>1</sub>" to "R<sub>4</sub>" each denotes a material selected from a group consisting of a hydroxy group, an alkylhydroxy group, a methoxy group, an ethoxy group, a hydrogen, an alkyl group ranging from 1 to about 20 carbons, a halogen group, a cyano group, a nitro group, an aryl group ranging from 6 to about 15 carbons, a fused aromatic group having a ring, an aromatic halide group, an alkylamine group, an aryloxy group, an arylamine group, an alkylepoxy group, a vinyl group, an alkylmercapto group, an acetoxy group, a siloxane group, and an imide group.

[0019] The present invention further provides a method of manufacturing an organic EL display, comprising: preparing

a substrate; forming a lower electrode over the substrate; forming an organic compound derivative layer over the lower electrode; forming a hole transport layer over the organic compound derivative layer; forming an organic light-emitting layer; forming an upper electrode over the organic light-emitting layer, wherein the organic compound derivative layer has the formula:



[0020] , wherein "M" denotes one metal selected from a group consisting of Ti, Pt and one metal among elements belonging to groups 3B and 4B of periods 3 to 5, and "R<sub>1</sub>" to "R<sub>4</sub>" each denotes a material selected from a group consisting of a hydroxy group, an alkylhydroxy group, a methoxy group, an ethoxy group, a hydrogen, an alkyl group ranging from 1 to about 20 carbons, a halogen group, a cyano group, a nitro group, an aryl group ranging from 6 to about 15 carbons, a fused aromatic group having a ring, an aromatic halide group, an alkyamine group, an aryloxy group, an arylamine group, an alkylepoxide group, a vinyl group, an alkylmercapto group, an acetoxy group, a siloxane group, and an imide group.

[0021] The metal M includes Si, Sn or Al. The device further comprises an electron injection layer. The organic compound derivative layer is formed using one of a dip coating technique, a spin coating technique, a roll coating technique, and a vacuum depositing technique. A thickness of the organic compound derivative layer is in a range between 1 Å to 1000 Å. A thickness of the organic compound derivative layer is within 100 Å. The organic compound derivative layer has a molecular weight ranging from about 100 to about 10,000 g/mol.

[0022] The organic compound derivative layer can further include a surfactant so as to lower a surface tension thereof. The surfactant includes a hydrophobic moiety such as an alkyl group, an alkylaryl group, a fluoroalkyl group, and an alkylsiloxane group, or a hydrophilic moiety such as a sulfate, a sulfonate, a carboxylate, an amide, a betainic structures, and a quarternized ammonium group. Preferably, the surfactant includes a nonionic hydrophobic moiety such as a polyether group and a nonionic fluoride-based surfactant. The surfactant having a relatively low concentration, is preferably in an amount ranging from about 0.1 wt % to about 0.3 wt %, and most preferably is about 0.2 wt %.

#### BRIEF DESCRIPTION OF THE DRAWINGS

[0023] For a more complete understanding of the present invention and the advantages thereof, reference is now made to the following descriptions taken in conjunction with the accompanying drawings, in which like reference numerals denote like parts, and in which:

[0024] FIG. 1 is a cross-sectional view illustrating a conventional organic EL display; and

[0025] FIG. 2 is a cross-sectional view illustrating an organic EL display according to the present invention.

#### DETAILED DESCRIPTION OF PREFERRED EMBODIMENTS

[0026] Reference will now be made in detail to a preferred embodiment of the present invention, example of which is illustrated in the accompanying drawing.

[0027] An organic EL display according to the present invention includes at least one organic compound derivative layer between an anode electrode and a cathode electrode, regardless of a stack structure or type of the organic EL display.

[0028] FIG. 2 is a cross-sectional view illustrating one embodiment of an organic EL display device according to the present invention, and particularly shows a high molecular organic EL display.

[0029] The organic EL display of FIG. 2 includes an anode electrode 22, an organic compound derivative layer 24, a hole transport layer 26, an organic light-emitting layer 28, and a cathode electrode 30 which are sequentially stacked on a substrate 20.

[0030] Even though arranged between the anode electrode 22 and the hole transport layer 26, the organic compound derivative layer 24 can be arranged between any two adjacent layers, e.g., the hole transport layer 26 and the organic light-emitting layer 28.

[0031] The organic compound derivative layer 24 has both a hydrophobicity and a hydrophilicity, and thus improves an interface characteristic between two layers abutting thereon. As a result, transportability of holes from the anode electrode 22 to the hole transport layer 26 is improved. Meanwhile, when additionally arranged between the cathode electrode 30 and the organic light-emitting layer 28, transportability of electrons from the cathode 30 to the organic light-emitting layer 28 is improved. Accordingly, a light emitting efficiency of the organic EL display is improved, leading to a high brightness.

[0032] The organic compound derivative layer 24 can be represented generally by Formula 1:



[0033] In Formula 1, "M" denotes one metal selected from a group consisting of Ti, Pt and one metal belonging to groups 3B and 4B of periods 3 to 5 of the periodic table. The metal M preferably includes Si, Sn or Al and more preferably Si. "R<sub>1</sub>" to "R<sub>4</sub>" each denotes a material selected from a group consisting of a hydroxy group, an alkylhydroxy group, a methoxy group, an ethoxy group, a hydrogen, an alkyl group ranging for 1 to about 20 carbons, a halogen group, a cyano group, a nitro group, an aryl group ranging 6 to about 15 carbons, a fused aromatic group having a ring, an aromatic halide group, an alkyamine group, an aryloxy group, an arylamine group, an alkylepoxide group, a vinyl group, an alkylmercapto group, an acetoxy group, a siloxane group, and an imide group.

[0034] Also, the organic EL device of the present invention further can comprise an electron injection layer.

[0035] The organic compound derivative layer may be formed using, e.g., a dip coating technique, a spin coating technique, a roll coating technique, or a vacuum depositing technique. The thickness of the organic compound derivative layer may range from several angstroms to thousands of angstroms. The organic compound derivative layer has a thickness preferably ranging from about 1 Å to about 1000 Å and most preferably about 100 Å.

[0036] Preferably, the organic compound derivative layer has a molecular weight ranging from about 100 to about 10,000 g/mol.

[0037] The organic compound derivative coated or deposited is cured by a heat treatment to provide a stable structure (i.e., network structure). In other words, since functional groups connected to a central metal M are substituents which are easily substituted after coating or deposition, the organic compound derivative layer forms a crosslinked structure through a substitution reaction and a condensation reaction as a result of heat treatment. Accordingly, the organic compound derivative layer has a stable molecular structure, i.e., network structure.

[0038] A contact angle of the organic compound derivative to water can be varied from 5° to 130° depending on the concentration and a polarity thereof. Hence, the surface energy of the organic compound derivative layer can be adjusted to be suitable for the layers that abut thereon. In other words, a bonding force between two layers interposing the organic compound derivative layer is improved, whereby the life span of the organic is increased.

[0039] In addition, when the organic compound derivative layer is arranged between the hole transport layer 26 and the organic light-emitting layer 28, since it has both a hydrophilic group and a hydrophobic group, the organic light-emitting layer can be formed on the hydrophilic hole transport layer using an ink-jet printing technique or a laser induced thermal imaging (LITI) technique. Accordingly, a full color light emission can be achieved by this simple process.

[0040] The organic compound derivative layer can further include a surfactant so as to lower the surface tension thereof. The surfactant includes a hydrophobic moiety such as an alkyl group, an alkylaryl group, a fluoroalkyl group, and an alkylsiloxane group, or a hydrophilic moiety such as a sulfate, a sulfonate, a carboxylate, an amide, a betainic structures, and a quarternized ammonium group. Preferably, the surfactant includes a non-ionic hydrophobic moiety such as a polyether group and a non-ionic fluoride-based surfactant. The surfactant having a relatively low concentration, is preferably in an amount ranging from about 0.1 wt % to about 0.3 wt %, and most preferably is about 0.2 wt %.

[0041] Embodiment 1

[0042] An anode electrode made of ITO is formed on a substrate to a thickness of 1500 Å to 2000 Å. Then, the substrate is cleaned in acetone and then UV/ozone-treated. A glycidoxypropyltrimethoxy silane (GPS) of 0.1 wt % is dissolved in an IPA/H<sub>2</sub>O solution having a PH 4 adjusted by an acetic acid and is hydrolyzed during one hour. The substrate is dipped in the GPS solution for 30 minutes, and thereafter is dried in a vacuum atmosphere at an atmospheric temperature, thereby forming an organic compound derivative layer having a thickness of 100 Å. Subsequently, a PEDOT is coated on the organic compound derivative layer at a speed of 3000 rpm. The coated PEDOT layer is baked at a temperature of 200° for five minutes to form a hole transport layer having a thickness of 500Å. An organic light-emitting layer is formed using a spin coating technique to a thickness of 800Å. A cathode electrode is then formed. The cathode electrode has a dual-layered structure of Ca and Ag. Finally, a metal cap layer is formed to encapsulate the organic EL display.

[0043] A light emitting efficiency of the organic EL display of Embodiment 1 is significantly improved. That is,

efficiency is increased from 3.5 cd/A to 4.6 cd/A. Further, the life span of the organic EL display is about twice that for conventional art.

[0044] As described herein before, employing the organic compound derivative layer according to 20 to the present invention, the organic EL display has a lengthy life span and a high brightness. Also, a full color light emission can be achieved by a simple process.

[0045] While the invention has been particularly shown and described with reference to preferred embodiments thereof, it will be understood by those skilled in the art that the foregoing and other changes in form and details may be made therein without departing from the spirit and scope of the invention.

What is claimed is:

1. An organic EL display, comprising:

an anode electrode;

a cathode electrode;

at least one organic layer selected from a hole transport layer, a hole injection layer, a light-emitting layer, an electron transporting layer, and an electron injection layer between the anode electrode and the cathode electrode; and

at least one organic compound derivative layer arranged between the anode electrode and the cathode electrode, the organic compound derivative layer having the formula:



, wherein "M" is one metal selected from the group consisting of Ti, Pt and one metal belonging to groups 3B and 4B of periods 3 to 5, and "R<sub>1</sub>" to "R<sub>4</sub>" each is a functional group selected from the group consisting of a hydroxy group, an alkylhydroxy group, a methoxy group, an ethoxy group, a hydrogen, an alkyl group ranging from 1 to about 20 carbons, a halogen group, a cyano group, a nitro group, an aryl group ranging from 6 to about 15 carbons, a fused aromatic group having a ring, an aromatic halide group, an alkylamine group, an aryloxy group, an arylamine group, an alkylperoxide group, a vinyl group, an alkylmercapto group, an acetoxy group, a siloxane group, and an imide group.

2. The display of claim 1, wherein the metal M is selected from the group consisting of Si, Sn, and Al.

3. The display of claim 1, wherein the organic compound derivative layer is formed using one of a dip coating technique, a spin coating technique, a roll coating technique, and a vacuum depositing technique

4. The display of claim 1, wherein a thickness of the organic compound derivative layer ranging from about 1 Å to about 1000 Å.

5. The display of claim 4, wherein the thickness of the organic compound derivative layer is about 100 Å.

6. The display of claim 1, wherein the organic compound derivative layer has a molecular weight ranging from about 100 to about 10,000 g/mol.

7. The display of claim 1, wherein the organic compound derivative layer is in contact with the anode electrode.

8. The display of claim 1, wherein the organic compound derivative layer is in contact with the cathode electrode.

9. The device of claim 1, wherein the organic compound derivative layer further includes a surfactant.

10. The device of claim 9, wherein the surfactant includes one selected from the group consisting of an alkyl group, an alkylaryl group, a fluoroalkyl group, and an alkylsiloxane group, a sulfate, a sulfonate, a carboxylate, an amide, a betainic structures, and a quarternized ammonium group.

11. The device of claim 9, wherein the surfactant includes a non-ionic surfactant.

12. The device of claim 11, wherein the non-ionic surfactant is a non-ionic fluoride-based surfactant.

13. The device of claim 9, wherein the surfactant is in an amount ranging from about 0.1 wt % to about 0.3 wt %.

14. A method of manufacturing an organic EL display, comprising:

preparing a substrate;

forming a lower electrode on the substrate;

forming an organic compound derivative layer on the lower electrode;

forming a hole transport layer on the organic compound derivative layer;

forming an organic light-emitting layer; and

forming an upper electrode on the organic light-emitting layer,

wherein the organic compound derivative layer has the formula:



, wherein "M" is one metal selected from the group consisting of Ti, Pt and one metal belonging to groups 3B and 4B of periods 3 to 5, and "R<sub>1</sub>" to "R<sub>4</sub>" each is a functional group selected from the group consisting of a hydroxy group, an alkylhydroxy group, a methoxy group, an ethoxy group, a hydrogen, an alkyl group ranging from 1 to about 20 carbons, a halogen group, a cyano group, a nitro group, an aryl group ranging from 6 to about 15 carbons, a fused aromatic group having a ring, an aromatic halide group, an alkyamine group, an aryloxy group, an arylamine group, an alkylperoxide group, a vinyl group, an alkylmercapto group, an acetoxo group, a siloxane group, and an imide group.

15. The method of claim 16, wherein the organic compound derivative layer further includes a surfactant.

16. The method of claim 15, wherein the surfactant includes one selected from the group consisting of an alkyl group, an alkylaryl group, a fluoroalkyl group, and an alkylsiloxane group, a sulfate, a sulfonate, a carboxylate, an amide, a betainic structures, and a quarternised ammonium group.

17. The method of claim 15, wherein the surfactant includes a non-ionic surfactant.

18. The method of claim 17, wherein the nonionic surfactant is a non-ionic fluoride-based surfactant.

19. The method of claim 16, wherein the surfactant is in an amount ranging from about 0.1 wt % to about 0.3 wt %.

\* \* \* \* \*

专利名称(译)	有机EL显示器及其制造方法		
公开(公告)号	<a href="#">US20030025445A1</a>	公开(公告)日	2003-02-06
申请号	US10/173680	申请日	2002-06-18
申请(专利权)人(译)	三星SDI CO. , LTD.		
当前申请(专利权)人(译)	三星DISPLAY CO. , LTD.		
[标]发明人	LEE JUN YEOB		
发明人	LEE, JUN-YEOB		
IPC分类号	H01L51/50 C09K11/06 H01L51/30 H05B33/00 H05B33/10 H05B33/14		
CPC分类号	C09K11/06 C09K2211/18 H01L51/0077 H01L51/0084 H01L51/5012 H05B33/14		
优先权	1020010046633 2001-08-01 KR		
其他公开文献	US7285904		
外部链接	<a href="#">Espacenet</a> <a href="#">USPTO</a>		

摘要(译)

有机EL显示器包括阳极;阴极;在阳极和阴极之间选自空穴传输层,空穴注入层,发光层,电子传输层和电子注入层中的至少一个有机层;在阳极和阴极之间设置至少一个有机化合物衍生物层,该有机化合物衍生物层具有下式结构:  $R_1R_2MR_3R_4$  式,其中“M”是选自Ti, Pt和属于第3至5族的3B和4B族的一种金属的一种金属。

